

Figure A

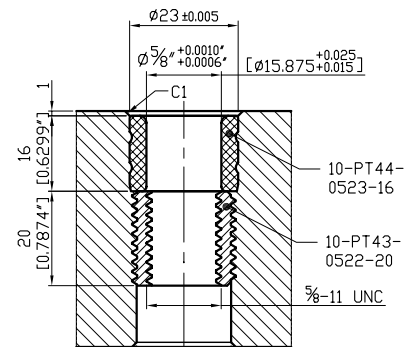

Figure B

\*Edge chamfered C2

Material FC300 CAST IRON		Heat treatment Annealing Process		Surface treatment		
Drafted by S.C.H	Checked by	Approved by	Scale 1/1	Date 2009.06.08	Sheet 1/1	Edition B
			TITLE M/C BASE PLATE			
			DWGNO. 10-BP15-40500-0500-5			