

1 2 3 4 5 6 7 8 9 10 11 12 13 14 15 16 17 18 19 20

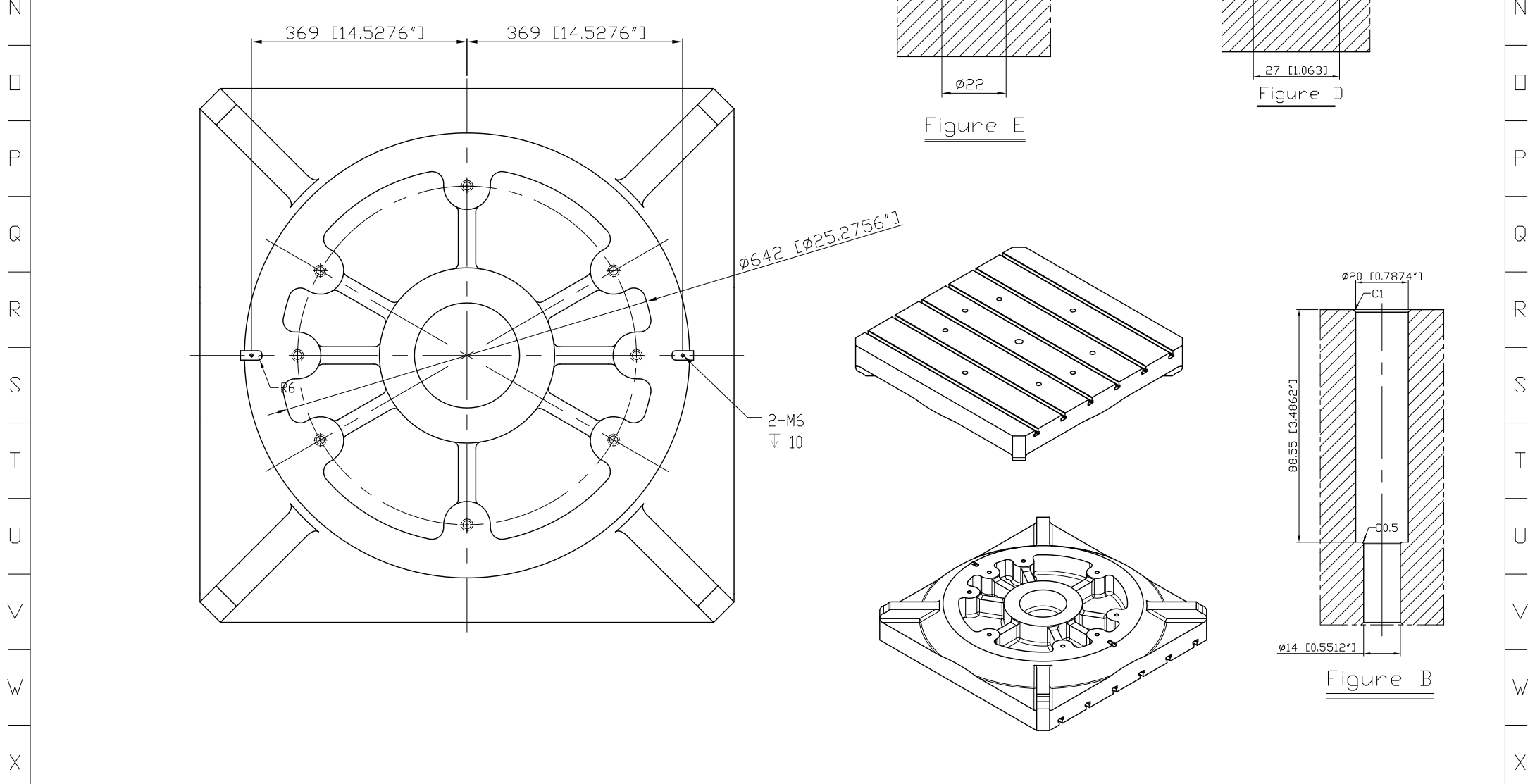
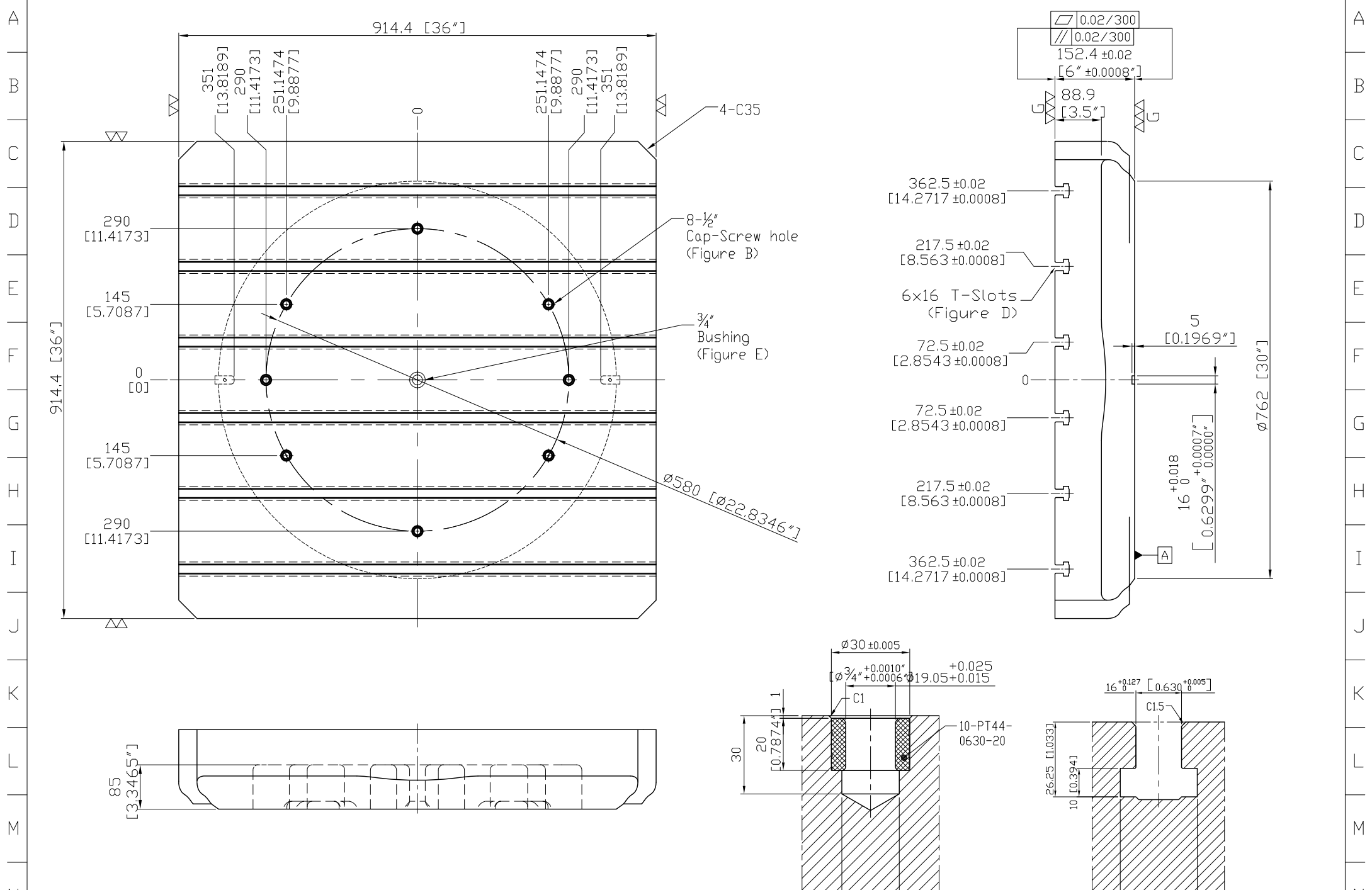

\*Edge chamfered C2

NW:687KG

Material FC300 CAST IRON		Heat treatment Annealing Process		Customer		
Drafted by C.Y	Checked by	Approved by	Scale 1/1	Date 2019.11.06	Sheet 1/1	Edition B
			TITLE HAAS EC-1600 RISER			
			DWG.NO. 10-BP18H-36-SQ			

1 2 3 4 5 6 7 8 9 10 11 12 13 14 15 16 17 18 19 20