

Figure A

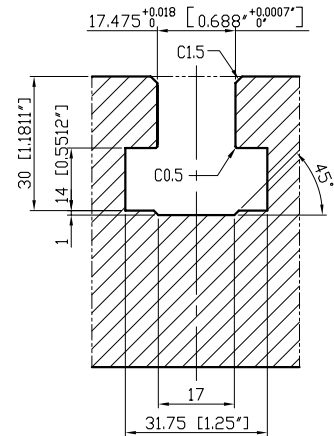
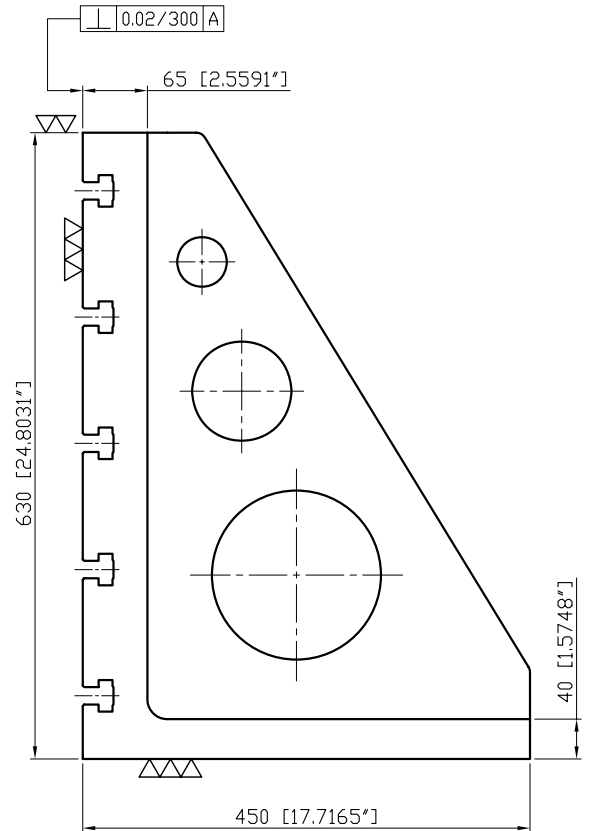
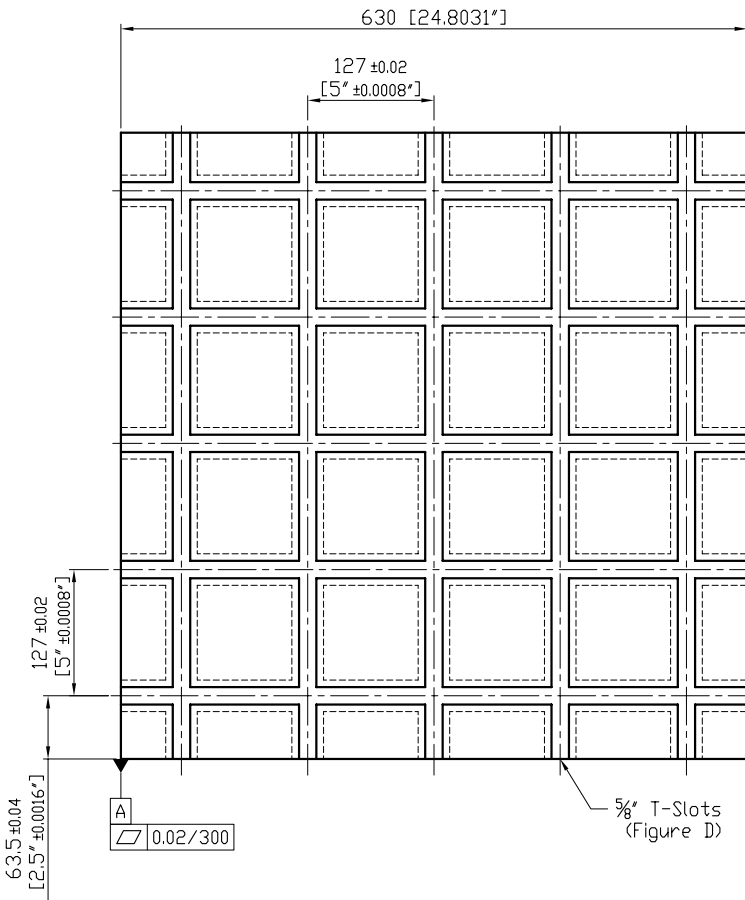

Figure D



Material FC300 CAST IRON		Heat treatment Annealing Process		Surface treatment		
Drafted by S.C.H	Checked by	Approved by	Scale 1/1	Date 2009.03.12	Sheet 1/1	Edition B
			TITLE M/C ANGLE PLATE			
			DWG.ND. 10-BP22-450630-0630-5			