

6-5/8"
Cap-Screw hole
(Figure A)

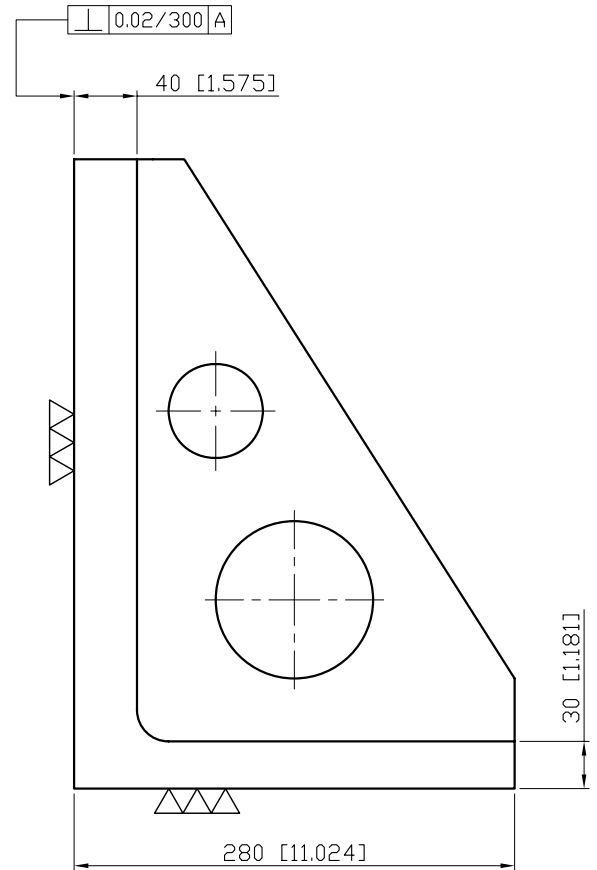
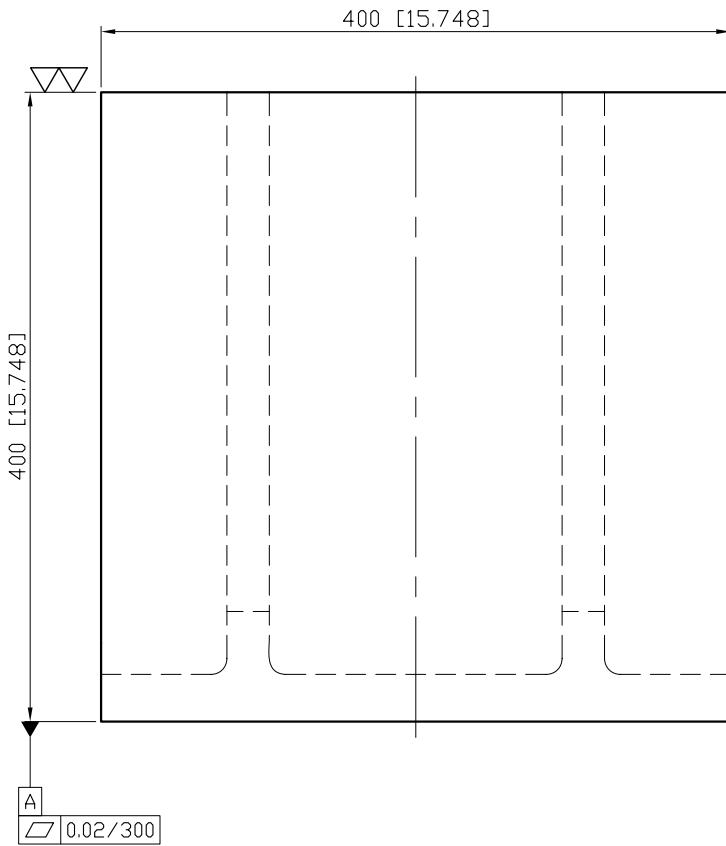
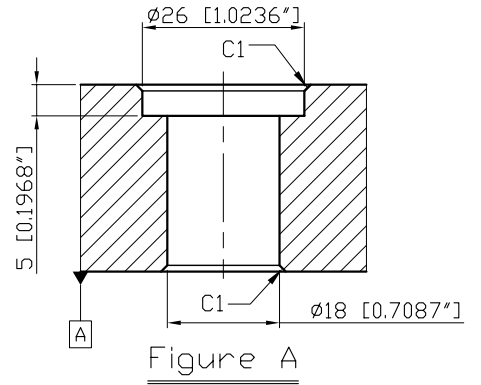

Material FC300 CAST IRON		Heat treatment Annealing Process		Surface treatment		
Drafted by S.C.H	Checked by	Approved by	Scale 1/1	Date 2009.04.16	Sheet 1/1	Edition B
			TITLE ANGLE PLATE			
			DWG.ND. BP20-280400-0400			